

Thank you for purchasing SacCityCorvette's Hardwire CoolIt
CoolIt H2 and H3 Installation Instructions (v10/14)

IMPORTANT!

We highly recommend that you test your CoolIt H2/H3 for compatibility and operation BEFORE you do the full install.
Follow this quick test procedure.

Full Color instructions are also at www.saccitycorvette.com

- 1) Remove your relay #43 and replace it with the CoolIt relay. You can verify which one is #43 by looking under the fuse box cover.
- 2) We have temporarily plugged the Blue switch wire onto the CoolIt Relay wire.
- 3) Start your Corvette up and let it idle.
- 4) Touch the Black switch wire to the **GROUND** on the battery as shown in picture.
NEVER apply power to the switch wires or CoolIt wire! It is **GROUNDED only!**
- 5) Turn switch ON/OFF, the Passenger side fan should respond.
- 6) If the fan turns on and off with the switch then your good to move on to the full installation on page 2. Otherwise contact us. Sale@saccitycorvette.com

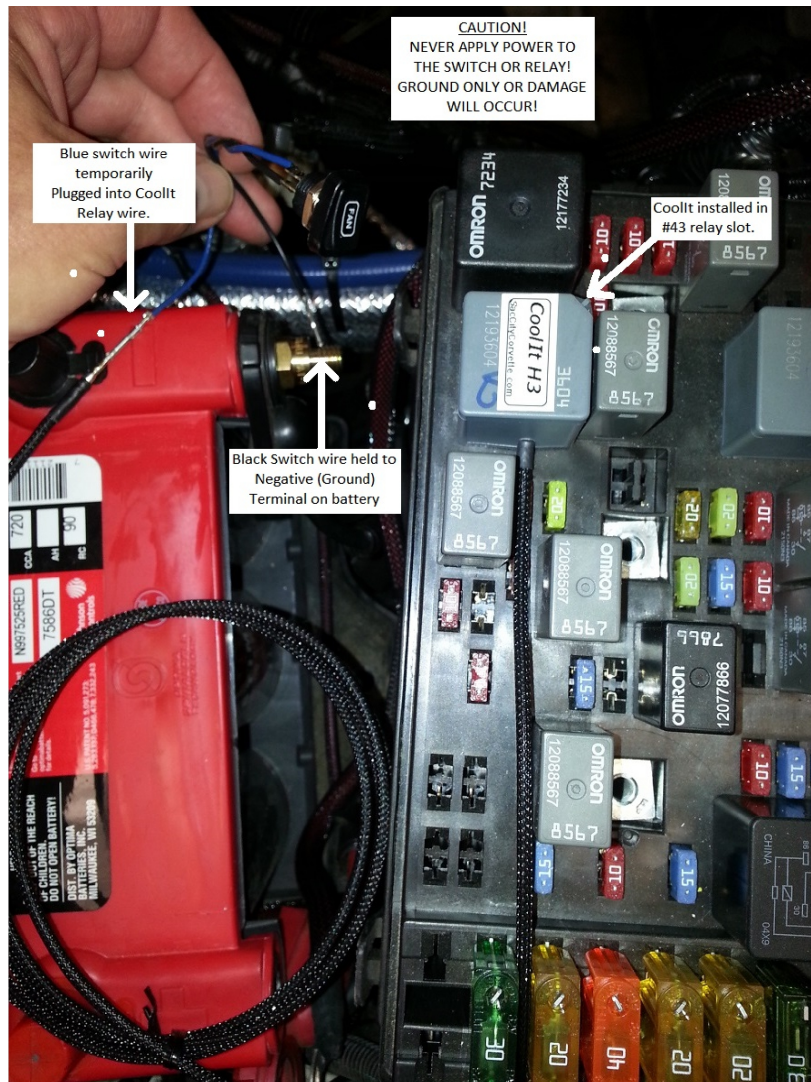

SacCityCorvette's Hardwire CoolIt H2/H3 Instructions

**Please follow instructions carefully or damage to your Corvette may occur!
Not following instructions will void Warranty! Read instructions before starting!**

Color instructions are also at www.saccitycorvette.com

We have designed this kit to be fool proof if you follow the instructions.

- 1) Remove battery so that you have access to the firewall behind the battery. Also remove the under hood fuse box cover.
- 2) In passengers foot well area, remove the under dash shroud and panel on floor that covers fuses so you can access area to drill 5/16" hole for CoolIt Relay wire to come through into passenger compartment. Make sure the other side of firewall is clear before drilling then drill hole. See Figure 1.
- 3) Remove #43 fan relay from under hood Fuse/Relay box and replace it with the CoolIt relay.
See #43 Relay location on Page 1. Route the wire neatly out of the way and through the hole you drilled in firewall.
Be gentle with this wire, it is a small gauge. See Figure 2.
- 4) From inside passenger compartment slide grommet on to CoolIt wire and into firewall. See Figure 3.
- 5) Once you have it through the fire wall you will need to decide where you want to mount the Switch and LED. See sample switch and LED install in a Zo6. See Figure 4.
- 6) Decide the location of the switch and LED and drill a 1/2" hole for switch and 1/4" hole for LED. The LED is a simple press in fit. Make sure you have enough clearance for the depth of the switch and the wires before you drill.
- 7) After switch and LED are installed plug the wires into the plastic connector **(A)** as shown in the wiring diagram.
See Figure 10
- 8) Route the CoolIt wire that you brought through the fire wall over to the switch and leave it there for now.
- 9) Drill 1/8" hole through BCM bracket for ground wire. See Figure 6
- 10) From wire harness **(B)** screw the Black ground wire ring terminal to BCM Bracket with supplied screw as shown in Figure 7
- 11) From wire harness **(B)** connect Red fused wire to fuse box. Plug into slot #22 as shown in Figure 7. If your #22 is not empty follow special instructions on wiring diagram. See Figure 10
- 12) Route harness **(B)** over to harness **(A)** and plug the CoolIt wire that you previously routed and plug it into harness **(B)**.
Connect harness **(A)** from switch to harness **(B)**. To test CoolIt, start car and turn CoolIt switch on. The right side fan should turn on in high speed mode and LED should be on. Don't forget, the fan will on every time you start the car unless switch is in the OFF position.
- 13) Lastly, cut small slot in under hood Fuse/Relay box and reinstall it. See Figures 8-10

**If you have any questions please call Tech Support at (916) 968-4451 or Email
Sales@saccitycorvette.com**

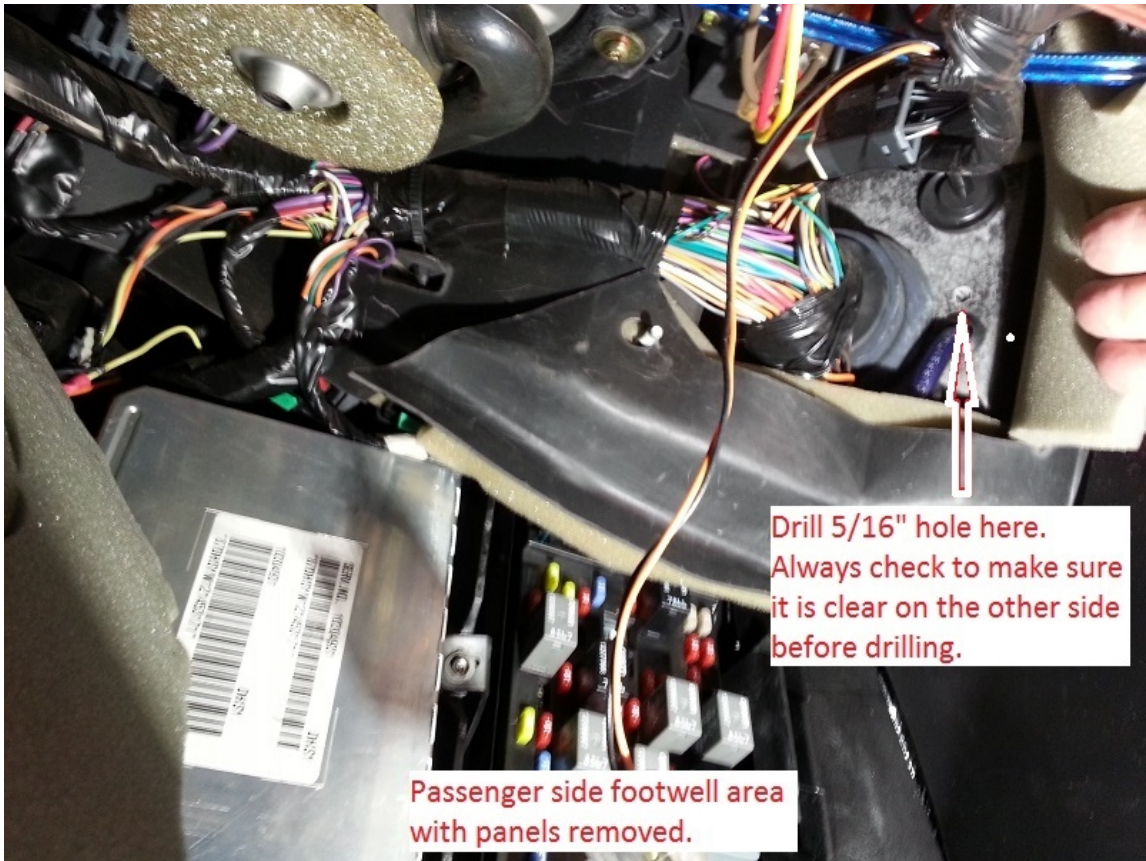

FIG. 1



FIG. 2
PAGE 3



FIG. 3



FIG. 4

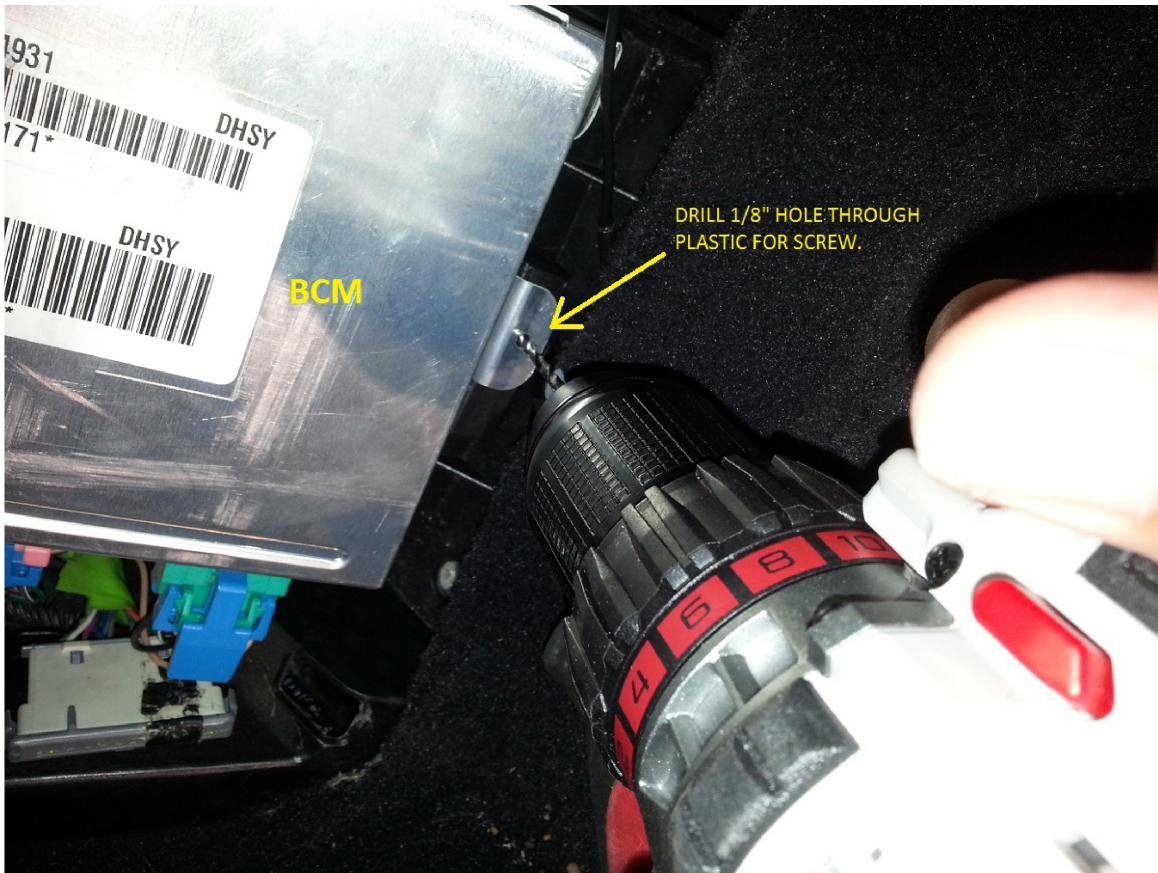

FIG. 5

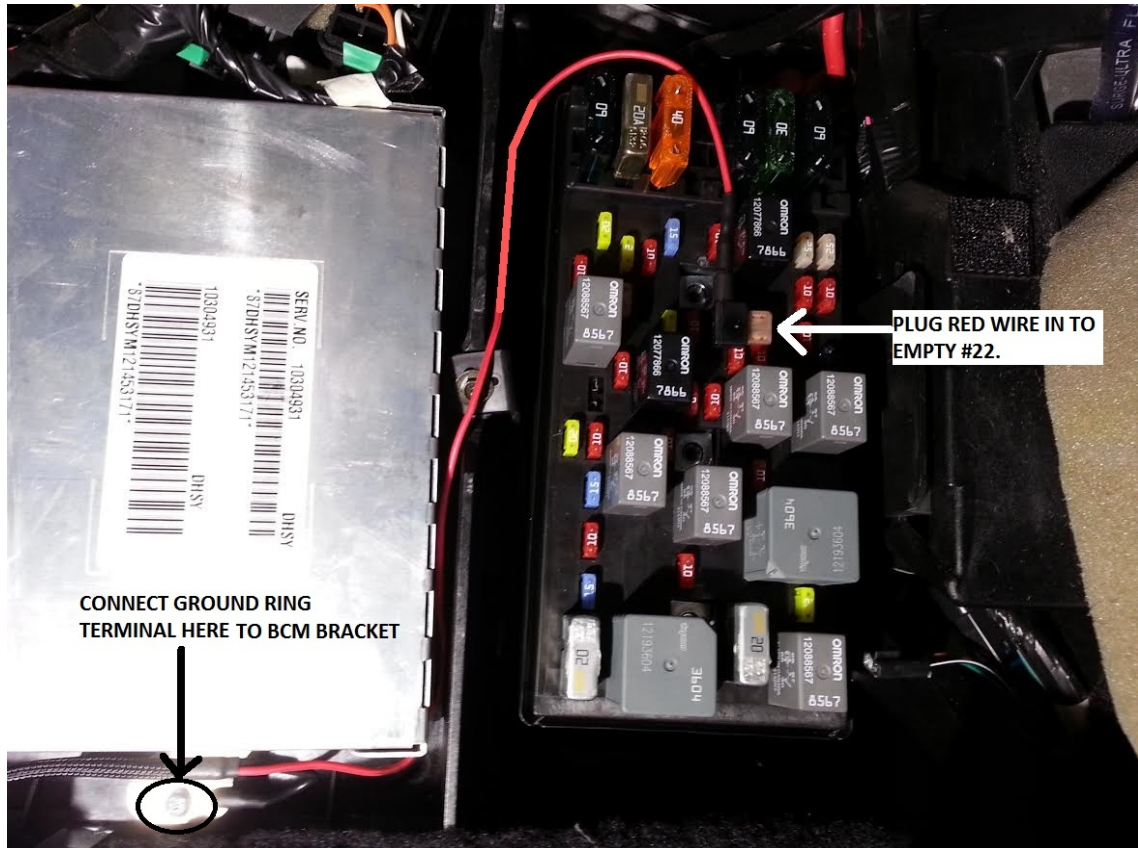

FIG. 6
PAGE 5

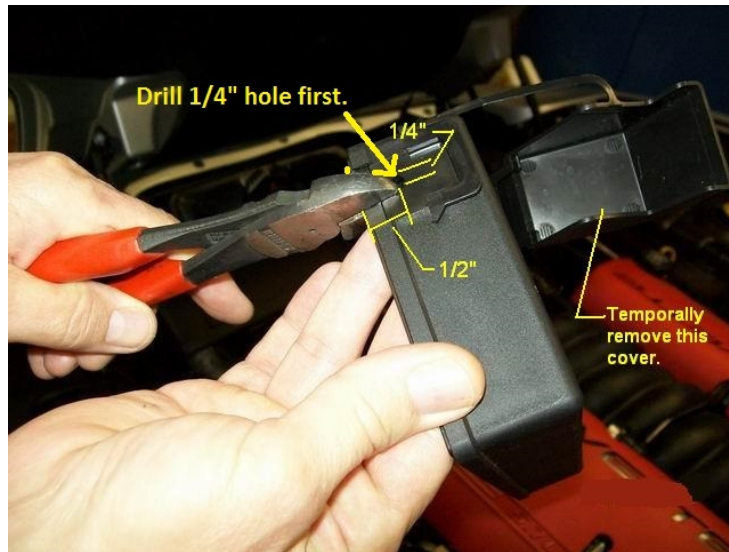

FIG. 7

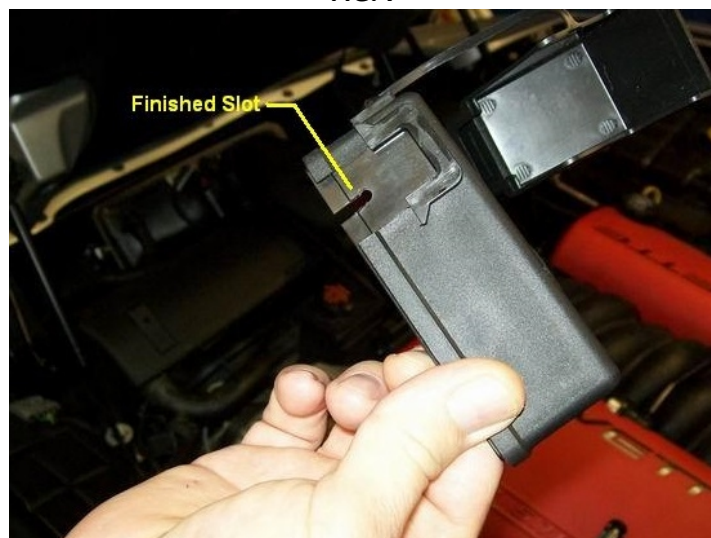

FIG. 8

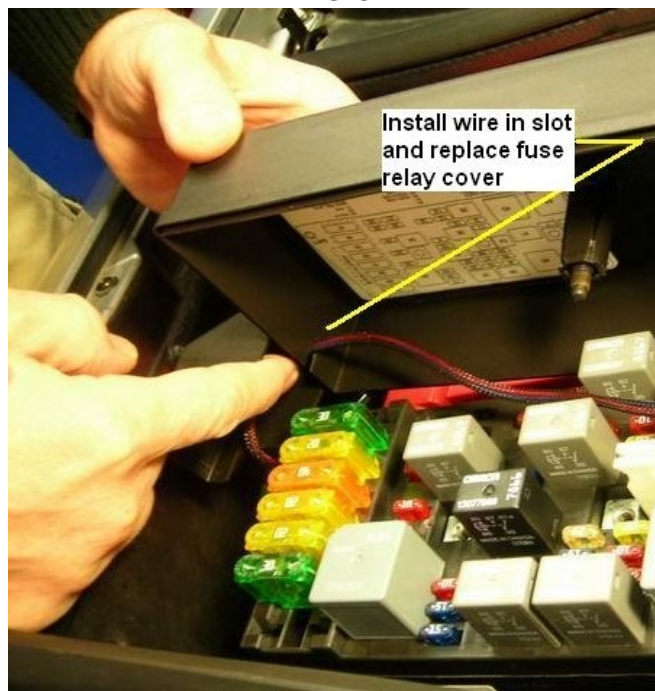
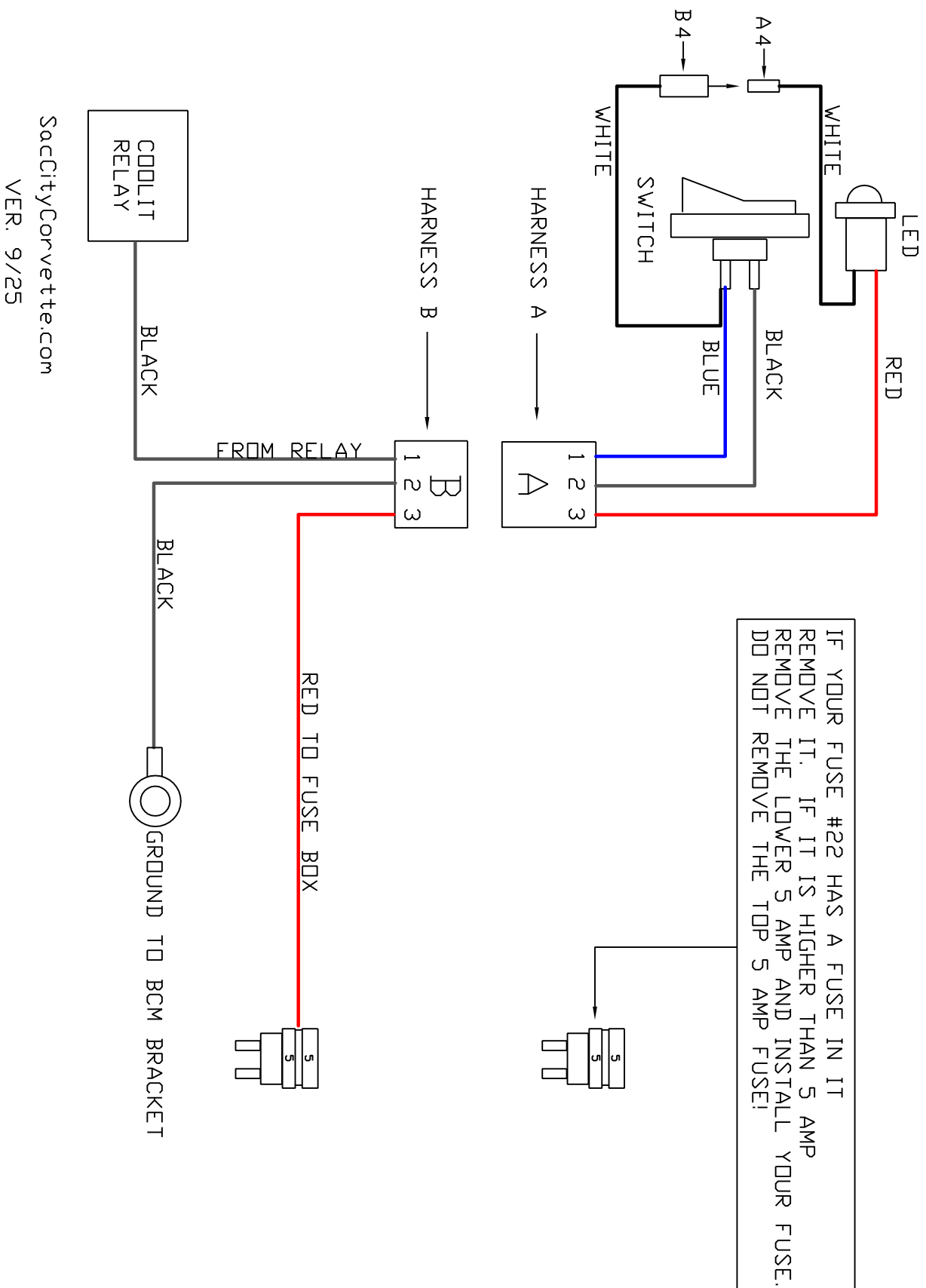

FIG. 9
PAGE 6P

Installation Wire Diagram For Hard Wire CoolIt



SacCityCorvette.com
VER. 9/25

FIG. 10